

# MAXJAX<sup>®</sup>

**LOW CEILINGS? NO PROBLEM!**



***New M7K Model***

***7,000 Lb. Capacity***

## **PORTABLE TWO-POST CAR LIFT**

***DURABLE | RELIABLE***

1-844-629-5291 • [www.maxjax.com](http://www.maxjax.com)

©2023 BendPak Holdings LLC. A wholly owned subsidiary of BendPak, Inc. Patent NO. US 8.256.577 B2 and US 9.150.395 B2.

# OVERVIEW

## The Patented One-of-a-Kind MaxJax® Portable Car Lift

- Safety Features from the Ground Up.
- No one in the industry has a more sophisticated and comprehensive research and quality control program than MaxJax, and our thousands of customers worldwide prove it.
- Low-pressure HVLP Direct-Drive cylinders eliminate the need for lifting chains or screw mechanisms most commonly found on other lift designs.
- Hydraulic cylinders feature integrated velocity-fuse safety valves.
- A robust, gear-type flow divider precisely distributes hydraulic pressure providing consistent, equalized lifting.
- Rugged safety lock bars are capable of holding three-times the rated lifting capacity.
- Arm restraints automatically engage each time the lift is raised.
- Detailed installation, maintenance and safety instructions accompany each MaxJax car lift.
- MaxJax encourages all owners to know their equipment and to follow good safety practices when using any of our products. Your MaxJax car lift equipment has been designed and built with your safety in mind, but the ultimate responsibility for safe operation is with you, the operator.

MaxJax is protected by one or more patents or claims of patents in the U.S. and elsewhere. This is provided to satisfy the virtual patent marking provisions of various jurisdictions, including the virtual patent marking provisions of the America Invents Act, as codified in 35 U.S.C. § 287(a).

PATENT NO. US 8.256.577 B2 and PATENT NO. US 9.150.395 B2

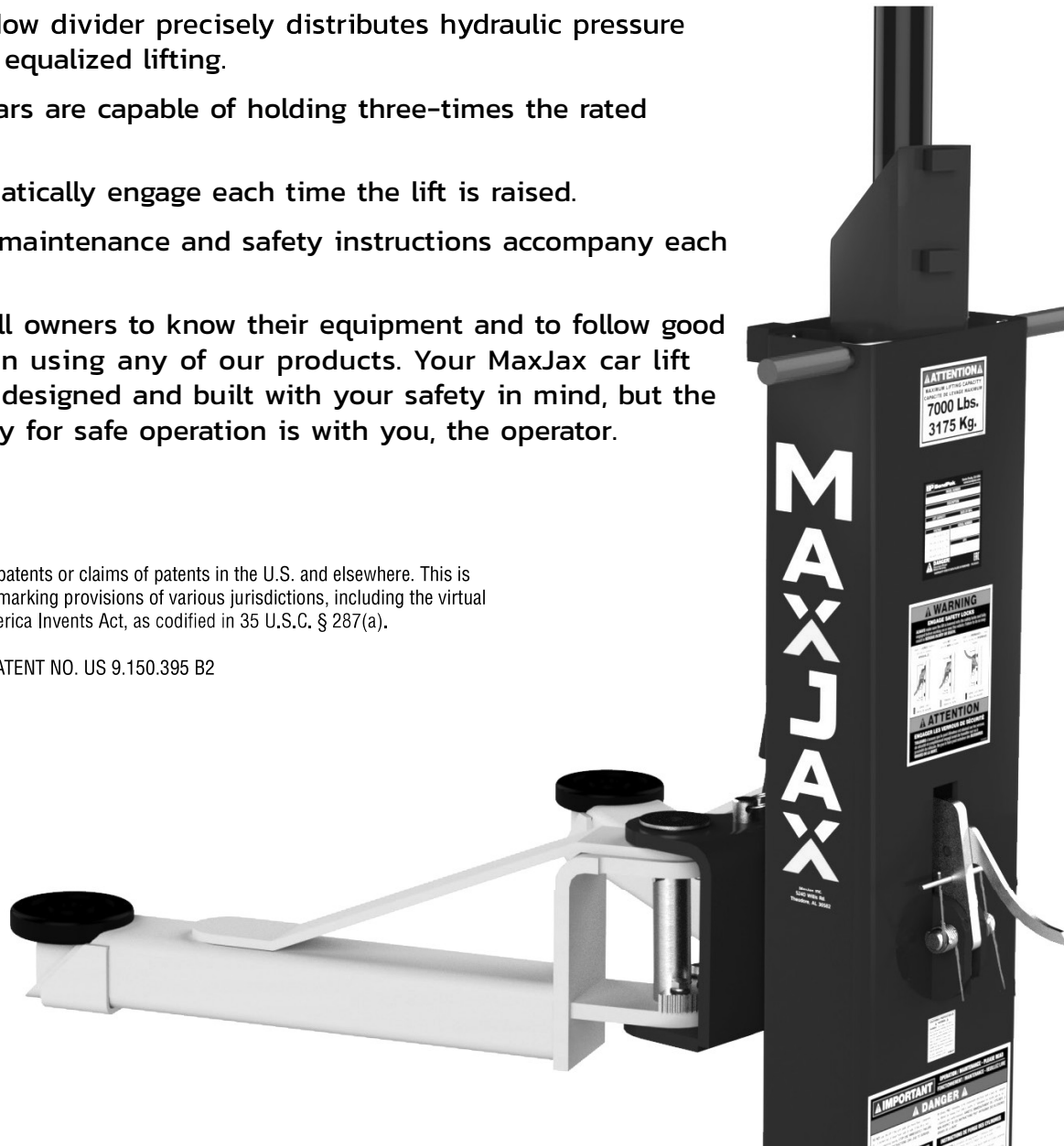

# FEATURES

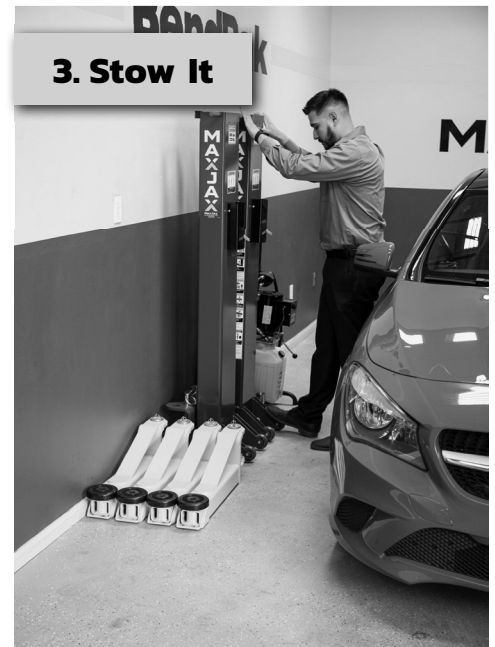
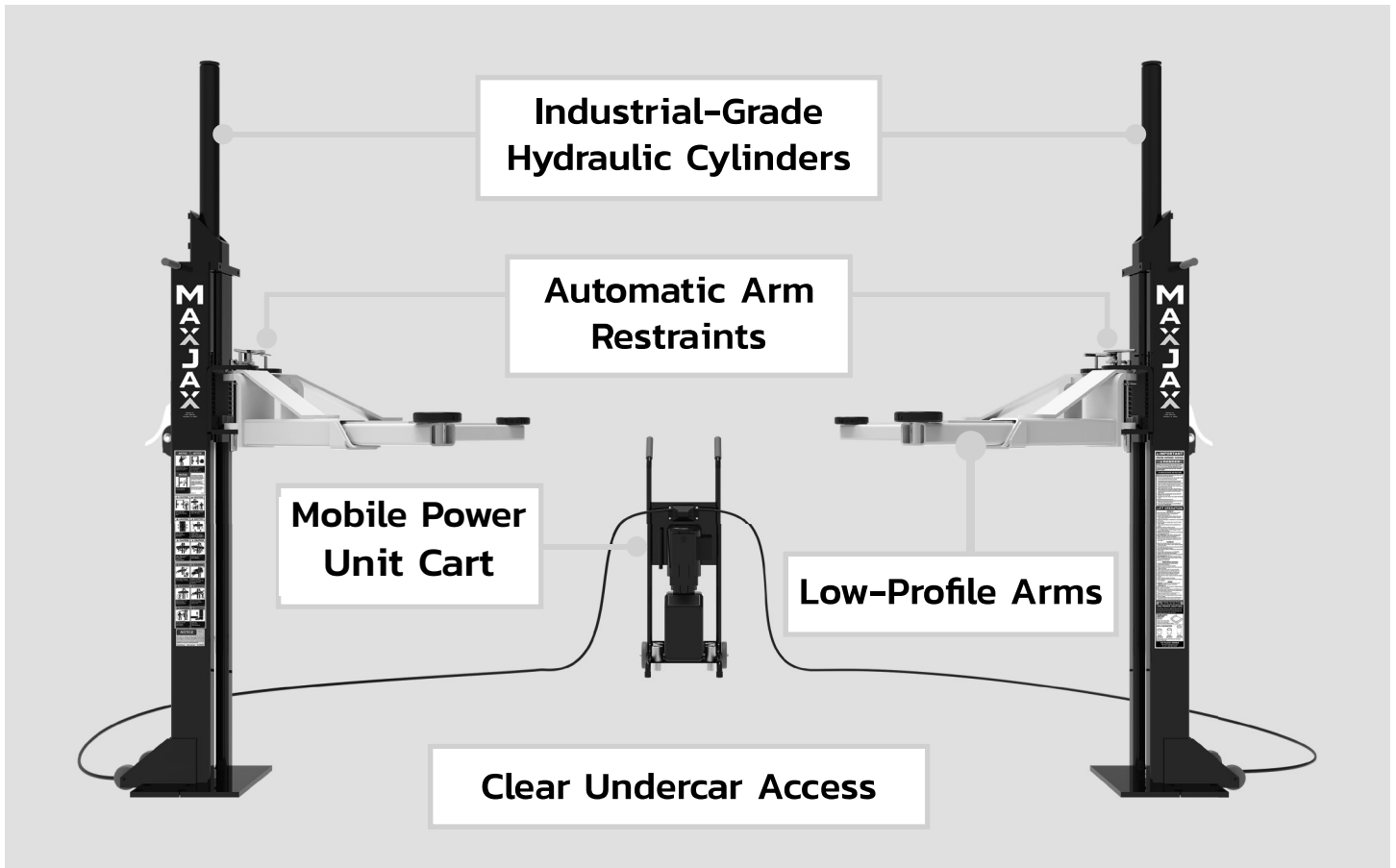

# PACKAGES

**GOOD**

## Deluxe Package

### Includes:

- M7K Portable Car Lift
- Upright Oil Drain
- Rolling Work Seat



**BETTER**

## Supreme Package

### Includes:

- M7K Portable Car Lift
- Upright Oil Drain
- Rolling Work Seat
- 5" Tall Adapter Pins
- Frame Cradle Pads



**BEST**

## Ultimate Package

### Includes:

- M7K Portable Car Lift
- Upright Oil Drain
- Adjustable Creeper
- 5" Tall Adapter Pins
- Frame Cradle Pads



# FEATURES



## BENEFITS OF THE MAXJAX

It's the features you get that set the MaxJax apart from the rest. Every MaxJax unit is loaded with the right features that make it the best choice when looking for a new car lift. Read through the long list of features this car lift has to offer and you'll easily come to the conclusion that the MaxJax is no ordinary garage lift.



## CLEAR UNDERCAR ACCESS

Want under-car clearance without having to rely on a permanent installation? That's where MaxJax comes in! No other low-rise or mid-rise lift system provides more under-car clearance and unobstructed floor space than the MaxJax lifting system. Now you can easily access engine undersides as well as critical components like transmissions, drive-shafts, starters, differentials, or anything else that would require under-car access.

## PORTABILITY

A two-post car lift with built-in wheels that allows you to use the lift when you need it, then conveniently store it out of the way when not in use keeping your garage and vehicle lanes clutter-free.



# FEATURES



## STOW TO GO IN LESS THAN 15-MINUTES

Internally threaded recessed drop-in anchors and quick-connect/disconnect hydraulic couplers provide for fast and simple set-up.

**NOTICE:** Before drilling into post-tension garage floors, always consult a building engineer to determine cable locations and where it is safe to drill.

## WORKS LIKE MAGIC

A robust, gear-type flow divider is the heart of the MaxJax system, providing consistent, equalized lifting. The specially designed flow divider/combiner is a positive-displacement fluid control device which allows precise distribution of hydraulic power to both columns even if load balance or pressures change.

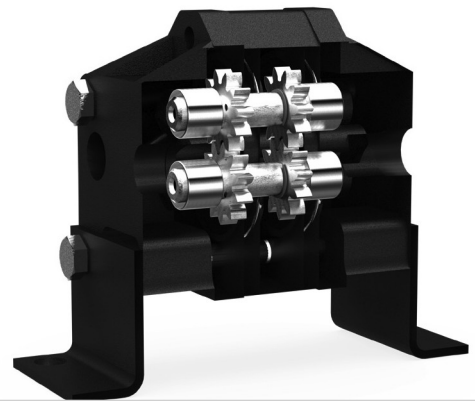

## MOBILE POWER UNIT CART



The great thing about our standard mobile power unit cart is that it's small enough to be stored out of the way and it features a storage area for the hydraulic hoses. The hydraulic power unit utilizes a single-phase motor that requires a standard 15 Amp 110-volt AC circuit. A 220VAC option is available. The industrial grade power cord is 6-ft. long. A simple push-button switch raises the lift, and a push lever controls the lowering. Simple quick-disconnect hoses can be positioned easily for single or dual column operation.

# FEATURES

## ADJUSTABLE LIFTING ARMS AND STACKABLE ADAPTERS

Increases overall arm positioning for lifting a variety of different vehicles that have Uni-body construction, OEM recommended pick-up points, or wide and/or narrow frame configurations. **Every MaxJax order includes four (4) medium height adapters and four (4) stackable standard lift pad adapters.**



## LOW-PROFILE ARMS

Fit under the lowest compact and sport vehicles or custom motorcycles with lowered frames.

## AUTOMATIC ARM RESTRAINTS

Each arm is equipped with durable arm restraints that automatically engage each time the lift is raised. When the lift is lowered, the gear type arm restraints automatically disengage to provide easy positioning of the lift arms.

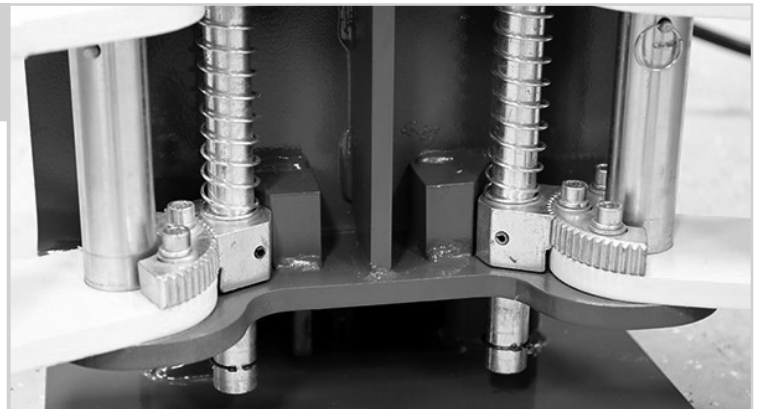

## MAINTENANCE-FREE SLIDE BLOCKS

Rather than using roller bearings that need constant lubrication and maintenance, we use futuristic full-floating UHMW ultra-high molecular weight polyethylene load bearings that last virtually the life of the lift.

# FEATURES

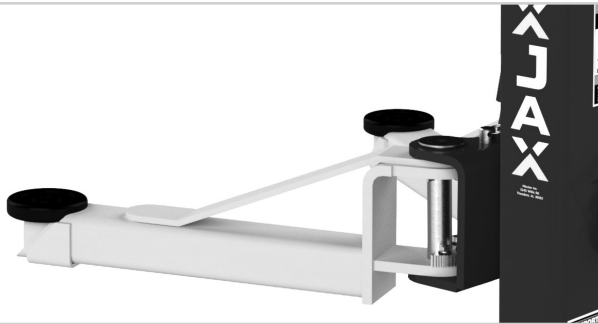

## SINGLE-PIECE COLUMNS

We purposely manufacture the columns using single-piece construction for added strength and less fatigue under heavy load conditions.

## DIRECT-DRIVE TECHNOLOGY

By utilizing two low-pressure HVLP Direct-Drive cylinders, we've eliminated the need for lifting chains or screw mechanisms most commonly found on other lift designs. HVLP Direct-Drive technology offers better reliability, smoother operation and less maintenance.

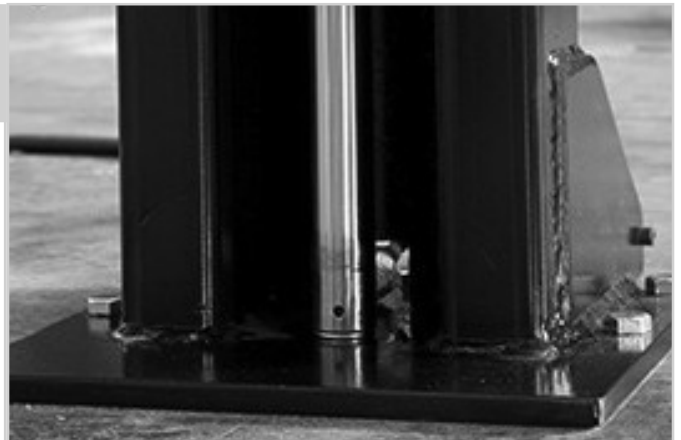

## INDUSTRIAL-GRADE HYDRAULIC CYLINDERS

Integrated into every MaxJax® hydraulic cylinder is a one-piece, pilot fitted, machined steel piston wrapped with specially designed, pressure loaded U-cup piston seals, backups and wear bands that virtually eliminates any fluid bypass. The micro-smooth chrome-plated rod is machined from high yield, ground and polished C-1045/50 micro-alloy steel and plated to a minimum of .001" diametrically, to ensure superior cylinder operation and life.

# ACCESSORIES

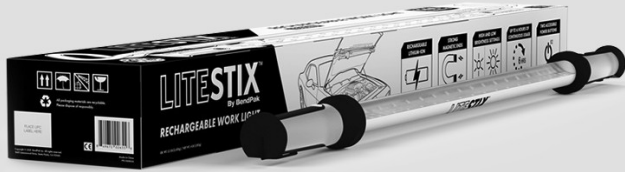

## LITESTIX™ LS36SMD

LITESTIX™ LS36SMD is a versatile LED portable work light designed for heavy-use. A total of 36 super-bright LED bulbs provide brilliant lighting coverage anywhere you need, perfect for night time and other low-light projects.

## ERGOCHAIR ERGO-RS

The Ergo-RS adjustable-height rolling work seat makes performing awkward work tasks ergonomically easier and safer for those who needs to lie down, bend or contort their body to perform repetitious work duties, especially car and aircraft mechanics, heavy-equipment technicians, factory and assembly line workers.



## RECLINING CREEPER SEAT

Our super-plush adjustable creeper seat is the must-have accessory for the MaxJax portable car lift. Easily converts from a low-profile creeper to a comfortable work seat allowing you to perform work under a lifted vehicle while being in extreme comfort.

## MOTORCYCLE / ATV ADAPTER

Our optional motorcycle adapter kit allows you to safely lift motorcycles, ATV's or other motorized vehicles to a comfortable working height.

- 1,500-lbs. capacity
- Simple Installation
- Non-slip polyurethane rubber pads
- Sturdy stainless steel construction



# SPECIFICATIONS

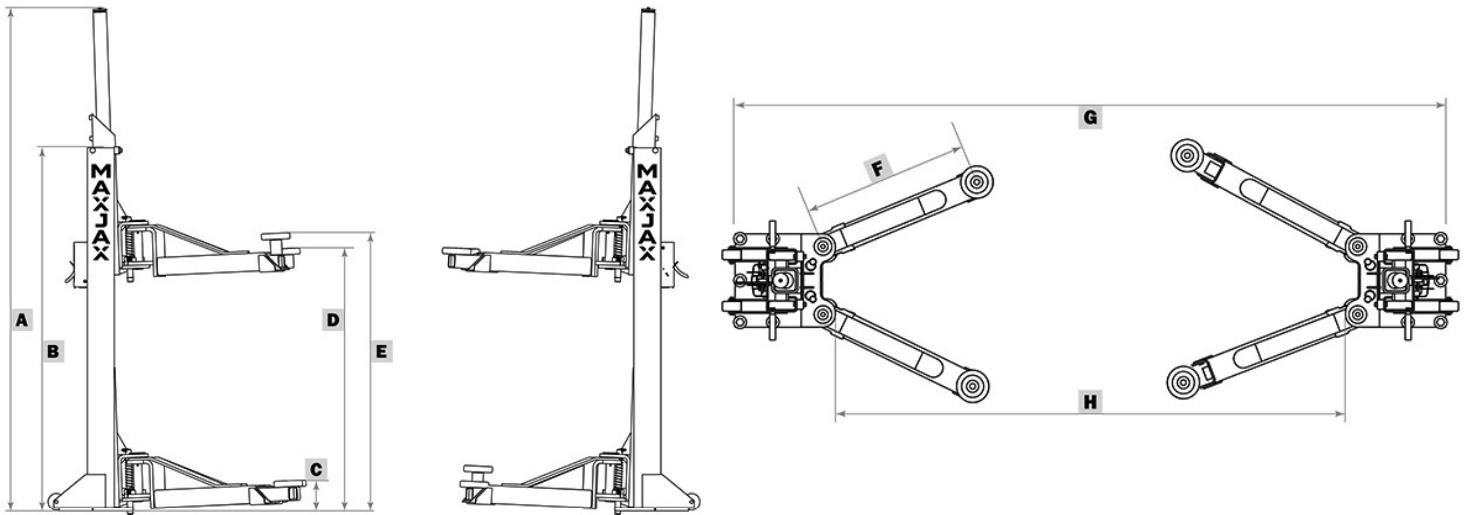

<b>Lifting Capacity</b>		7,000 lbs. (2,722 kg)
<b>Max. Load Per Arm</b>		1,750 lbs. (794 kg)
<b>A</b>	<b>Height Overall</b>	89.5" (2,273 mm)
<b>B</b>	<b>Height of Column</b>	64" (1,626 mm)
<b>C</b>	<b>Min. Pad Height</b>	5.5" (139.7 mm)
<b>D</b>	<b>Max. Lift Height (Pad Only)</b>	47.25" (1200.15 mm)
<b>E</b>	<b>Max. Lift Height (With 3" Adapter)</b>	50.5" (1,283 mm)
<b>F</b>	<b>Arm Reach (Min. - Max.)</b>	26" - 40" (660 mm - 1,016 mm)
<b>G</b>	<b>Typical Width (Outside of Base Plate)</b>	105" - 135" (2,667 mm - 3,429 mm)
<b>H</b>	<b>Drive-thru clearance</b>	74" - 104" (1,880 mm - 2,642 mm)
<b>Locking Positions</b>		8 (every 3")
<b>Motor</b>		110 VAC / 50-60 Hz. / 1 Ph. (15A Breaker)
<b>Time to full Rise</b>		45-seconds
<b>Individual Column Weight</b>		300 lbs. (136 kg)
<b>Shipping Weight (Standard Model)</b>		980 lbs. (444 kg)
<b>Shipping Dimensions (Standard Model)</b>		68" x 39" x 35" (1,727 mm x 990.6 mm x 889 mm)

# SPECIFICATIONS

## Baseplate dimensions\*

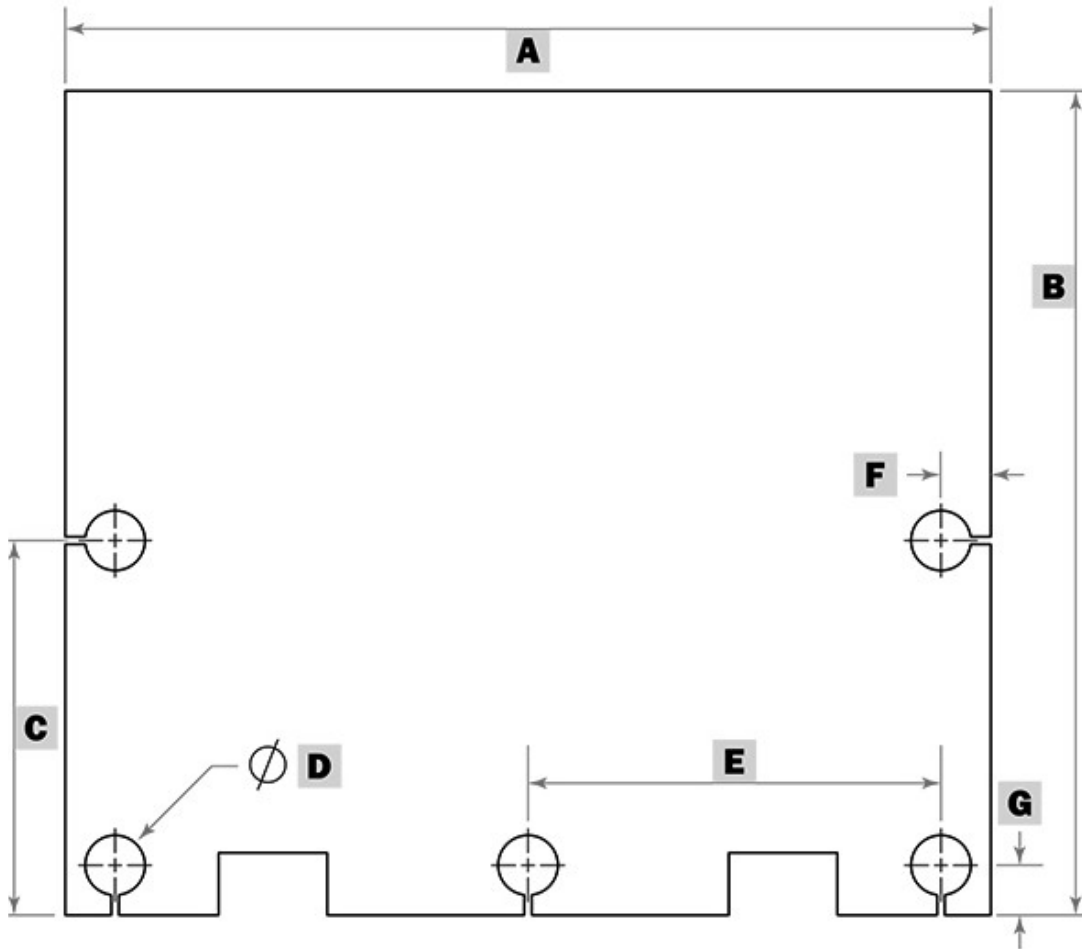

<b>A</b>	14.5" (371 mm)
<b>B</b>	13" (330 mm)
<b>C</b>	6" (150 mm)
<b>D</b>	1" (24 mm)
<b>E</b>	6.5" (165.5 mm)
<b>F</b>	0.75" (20 mm)
<b>G</b>	0.75" (20 mm)

\*For reference purposes only.

# PHOTO GALLERY

